

ValuLine® High Performance, Point-to-Point Microwave Antenna

Low profile, single-polarized, high performance parabolic shielded antenna



Andrew Solutions VHLP Series antennas are ideal for microwave applications demanding excellent pattern performance where space is at a premium and aesthetics are important

Andrew Solutions specially engineered family of ValuLine Antennas provides exceptional performance and value in a low-profile design. In addition, ValuLine Antennas are designed to easily integrate with radio outdoor units to create a highly reliable, cost-effective transmission solution.

Andrew Solutions designs and engineers a complete range of point-to-point microwave antennas that help operators to maximize bandwidth efficiency and increase system reliability while minimizing both capital and operational expenditures.

The intelligent design of VHLP antennas combines efficient beam-forming capabilities with high gain, all while minimizing frequency congestion. Equipped with a painted reflector, each antenna also features a high efficiency feed system, a long life radome, and vertical pipe mount. All are engineered and tested to Andrew's uncompromising standards.

Radiation Pattern Envelopes—For each antenna model, Andrew publishes a complete range of radiation pattern envelopes (RPEs). Each detailed pattern envelope provides an easy-to-read and informative description of how the antenna performs at various frequencies and along specific planes. Copies of the RPEs for each antenna are also on file at various regulatory offices around the world.

- Ideal for high density areas where space is at a premium and aesthetics are important
- Integrates easily with radio outdoor units
- Single polarized operation
- Low lifetime cost

Product Specifications



VHLP3-1 1W-6GR

1.0 m | 3 ft ValuLine® High Performance Low Profile Antenna, single-polarized, 10.125–11.700 GHz, CPR90G, gray antenna, polymer gray radome without flash, standard pack—one-piece reflector

CHARACTERISTICS

General Specifications

Antenna Input	CPR90G
Packing	Standard pack
Radome Color	Gray
Radome Material	Polymer
Reflector Construction	One-piece reflector
Antenna Color	Gray
Antenna Type	VHLP - ValuLine® High Performance Low Profile Antenna, single-polarized
Diameter, nominal	1.0 m 3 ft
Flash Included	No
Polarization	Single

Electrical Specifications

Beamwidth, Horizontal	2.0 °
Beamwidth, Vertical	2.0 °
Cross Polarization Discrimination (XPD)	30 dB
Electrical Compliance	Brazil Anatel Class 2 Canada SRSP 310.5 ETSI 302 217 Class 3 US FCC Part 101A US FCC Part 101B
Front-to-Back Ratio	64 dB
Gain, Low Band	37.2 dBi
Gain, Mid Band	38.4 dBi
Gain, Top Band	39.0 dBi
Operating Frequency Band	10.125 – 11.700 GHz
Radiation Pattern Envelope Reference (RPE)	7164 7166
Return Loss	17.7 dB
VSWR	1.30

Mechanical Specifications

Fine Azimuth Adjustment	±15°
Fine Elevation Adjustment	±15°
Mounting Pipe Diameter	115 mm 4.5 in
Net Weight	24 kg 53 lb
Side Struts, Included	0
Side Struts, Optional	1 inboard
Wind Velocity Operational	180 km/h 112 mph

www.commscope.com/andrew

©2011 CommScope, Inc. All rights reserved.

All trademarks identified by ® or ™ are registered trademarks or trademarks, respectively, of CommScope. All specifications are subject to change. See www.commscope.com/andrew for the most current information.

page 2 of 6
3/4/2011

Product Specifications

VHLP3-11W-6GR



Wind Velocity Survival Rating 250 km/h | 155 mph

Wind Forces At Wind Velocity Survival Rating

Angle α for MT Max	0 °
Axial Force (FA)	2979 N 670 lbf
Side Force (FS)	936 N 210 lbf
Twisting Moment (MT)	1184 N•m
Weight with 1/2 in (12 mm) Radial Ice	46 kg 101 lb
Zcg with 1/2 in (12 mm) Radial Ice	220 mm 9 in
Zcg without Ice	324 mm 13 in

Product Specifications

VHLP3-11W-6GR



Wind Forces At Wind Velocity Survival Rating Image

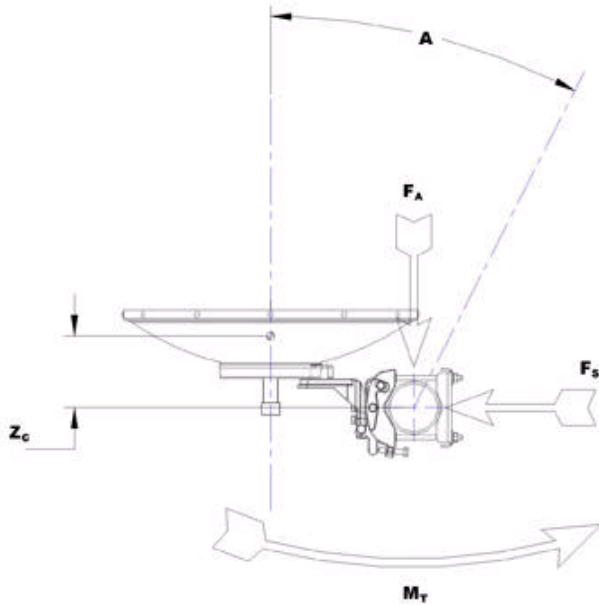

Packed Dimensions

Gross Weight, Packed Antenna	30.8 kg 67.9 lb
Height	106.3 cm 41.9 in
Length	119.8 cm 47.2 in
Volume	467365.0 cc
Width	36.7 cm 14.4 in

www.commscope.com/andrew

©2011 CommScope, Inc. All rights reserved.

All trademarks identified by ® or ™ are registered trademarks or trademarks, respectively, of CommScope. All specifications are subject to change. See www.commscope.com/andrew for the most current information.

page 4 of 6
3/4/2011

Product Specifications

VHLP3-11W-6GR

Antenna Dimensions And Mounting Information

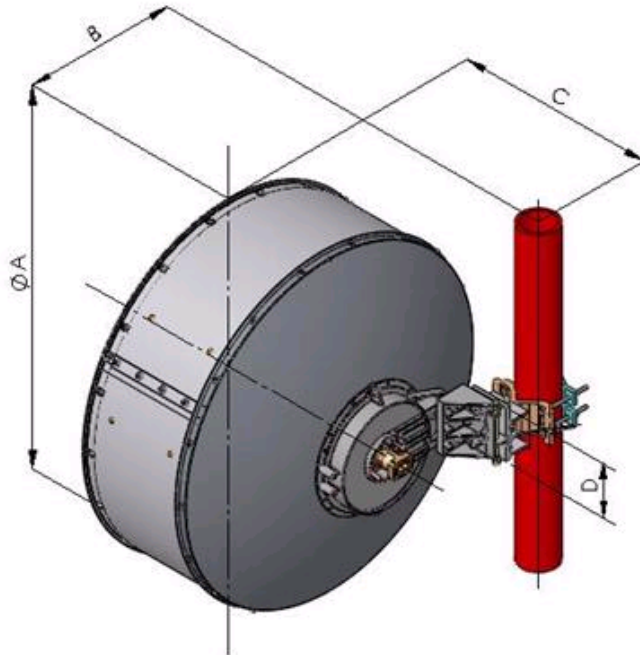

Dimensions in Inches (mm)				
Antenna Size, ft (m)	A	B	C	D
3(0.9)	39.4 (1000)	17.5 (445)	24.3 (617)	6.3 (160)

Regulatory Compliance/Certifications

Agency	Classification
ISO 9001:2008	Designed, manufactured and/or distributed under this quality management system

* Footnotes

Axial Force (FA)	Maximum forces exerted on a supporting structure as a result of wind from the most critical direction for this parameter. The individual maximums specified may not occur simultaneously. All forces are referenced to the mounting pipe.
Cross Polarization Discrimination (XPD)	The difference between the peak of the co-polarized main beam and the maximum cross-polarized signal over an angle twice the 3 dB beamwidth of the co-polarized main beam.
Front-to-Back Ratio	Denotes highest radiation relative to the main beam, at $180^\circ \pm 40^\circ$, across the band. Production antennas do not exceed rated values by more than 2 dB unless stated otherwise.

www.commscope.com/andrew

Product Specifications

VHLP3-11W-6GR



Gain, Mid Band	For a given frequency band, gain is primarily a function of antenna size. The gain of Andrew antennas is determined by either gain by comparison or by computer integration of the measured antenna patterns.
Operating Frequency Band	Bands correspond with CCIR recommendations or common allocations used throughout the world. Other ranges can be accommodated on special order.
Packing	Andrew standard packing is suitable for export. Antennas are shipped as standard in totally recyclable cardboard or wire-bound crates (dependent on product). For your convenience, Andrew offers heavy duty export packing options.
Radiation Pattern Envelope Reference (RPE)	Radiation patterns determine an antenna's ability to discriminate against unwanted signals under conditions of radio congestion. Radiation patterns are dependent on antenna series, size, and frequency.
Return Loss	The figure that indicates the proportion of radio waves incident upon the antenna that are rejected as a ratio of those that are accepted.
Side Force (FS)	Maximum side force exerted on the mounting pipe as a result of wind from the most critical direction for this parameter. The individual maximums specified may not occur simultaneously. All forces are referenced to the mounting pipe.
Twisting Moment (MT)	Maximum forces exerted on a supporting structure as a result of wind from the most critical direction for this parameter. The individual maximums specified may not occur simultaneously. All forces are referenced to the mounting pipe.
VSWR	Maximum; is the guaranteed Peak Voltage-Standing-Wave-Ratio within the operating band.
Wind Velocity Operational	The wind speed where the antenna deflection is equal to or less than 0.1 degrees. In the case of ValuLine antennas, it is defined as a maximum deflection of 0.3 x the 3 dB beam width of the antenna.
Wind Velocity Survival Rating	The maximum wind speed the antenna, including mounts and radomes, where applicable, will withstand without permanent deformation. Realignment may be required. This wind speed is applicable to antenna with the specified amount of radial ice.